

# WOOFERS

The radically improved DWC subs are Dragster's flagship in SPL arena. The revolution is here featuring technologies not yet seen. Due to a new concept design, the suspension is fixed to a metal ring outside the cone, so the diaphragm area covers almost all the overall dimension of the woofer both in 12" and 15". The DWC228.1 by 12" has a similar area than the previous DWC258 by 15", while the DWC258.1 has a diaphragm similar to an 18" woofer. This means a tremendous power capability supported by the enormous magnetic motor.

## EXTREME

# DWC series

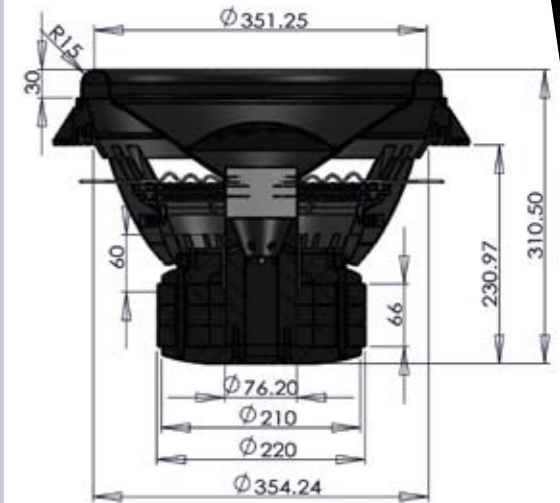
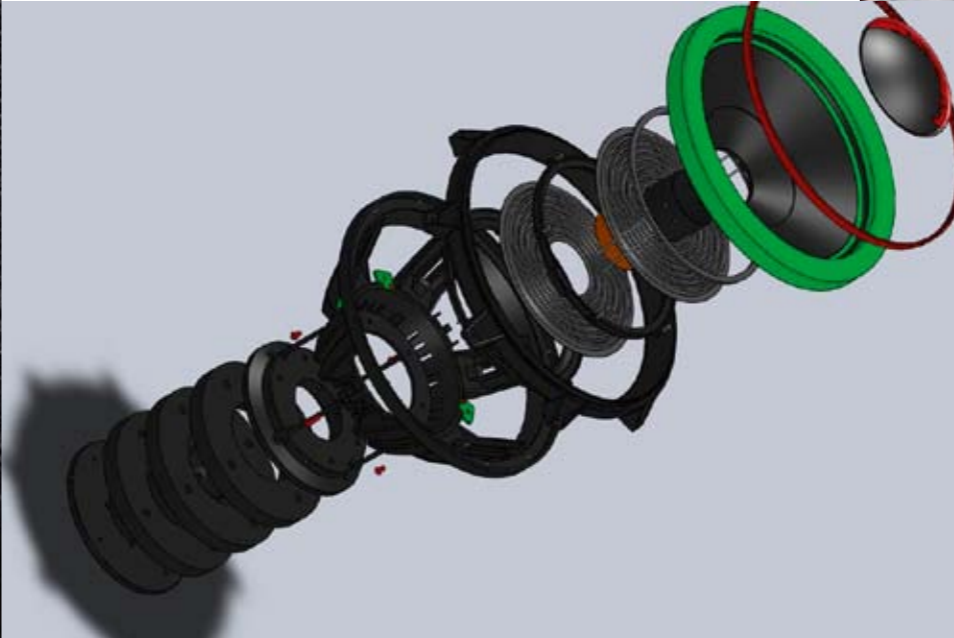
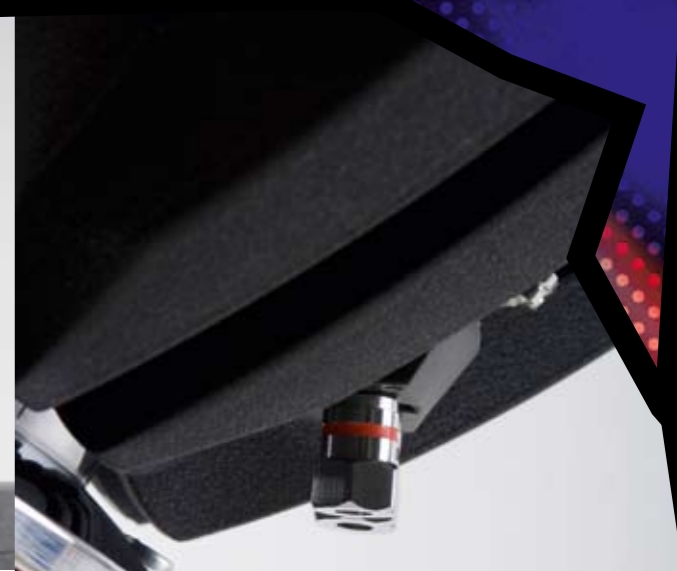

### DWC 228.1

300mm or 12", 0.5+0.5 ohm or 2+2 ohm  
2000W RMS, 4000W peak, 10000W short burp 3"

### DWC 258.1

380mm or 15", 0.5+0.5 ohm or 2+2 ohm  
2000W RMS, 4000W peak, 10000W short burp 3"

### HIGHLIGHTS

- ✓ non pressed cellulose cone
- ✓ DVC 2+2 ohm or 0.5+0.5 ohm
- ✓ V-Styrofoam surround w/vertical fixing
- ✓ OFC 8 gauge copper cable leads
- ✓ voice coil 3"
- ✓ aluminum voice coil former
- ✓ 4-layer aluminum coil
- ✓ dual CONEX spider
- ✓ 9" diameter triple magnet
- ✓ heavy duty die-cast aluminum frame
- ✓ reconing kit available

